

SKYROOM

INSTALLATION MANUAL

ATLAS
Aluminium

RINGBEAM & BOX GUTTER ASSEMBLY

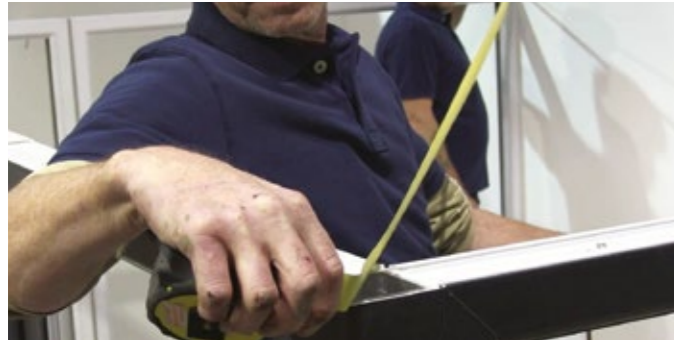

1 Check that frames are square by measuring equal distances from corner to corner.



2 Remove the ringbeam flaps from the ringbeam.



7 Lift the final front ringbeam into position and slide the ringbeam bracket into the channel on the



8 Fix the ringbeam to the window frames around the perimeter of the Skyroom roof.



3 Lift the rear box gutter including the ringbeam and place it on top of the side window frames.



4 Centre the gutter on the frames.



9 Fix the box gutter securely to the rear wall (see Figure 1).



10 Position the ringbeam flaps into place. Flap engages at approximately 90°.

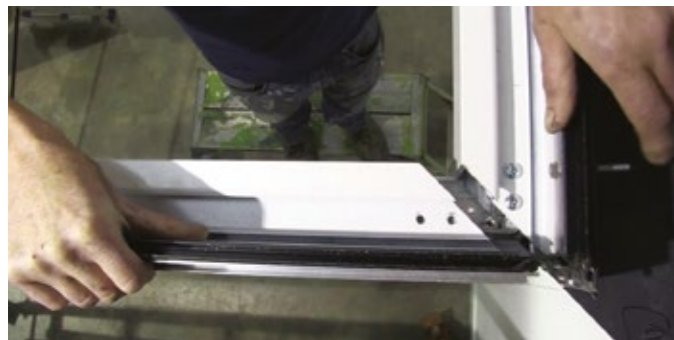

5 Slide the ringbeam bracket into the channel on the adjoining rear ringbeam.

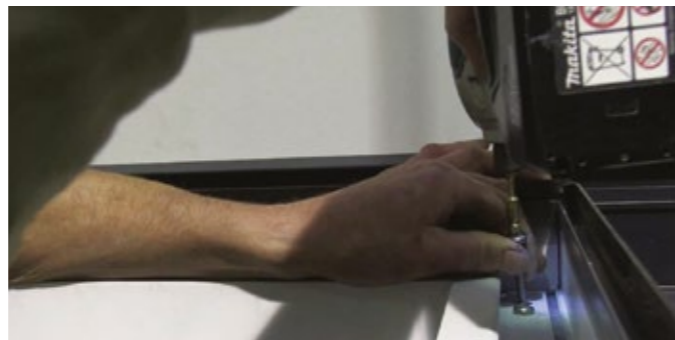

6 Fix the ringbeam screws into predrilled holes from above.

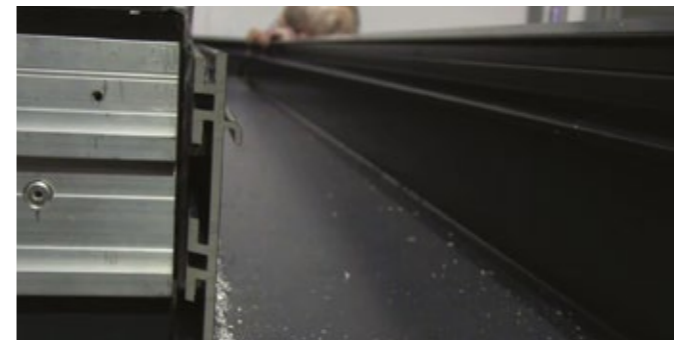

11 Lift the side gutters into place, by hooking them onto the hanger plate fixed to the ringbeam.

SKYROOM REAR BOX GUTTER SECTION

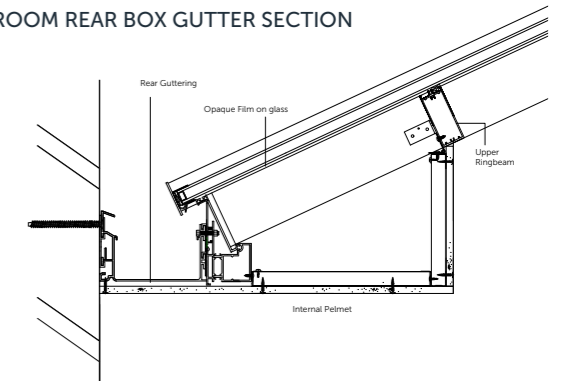
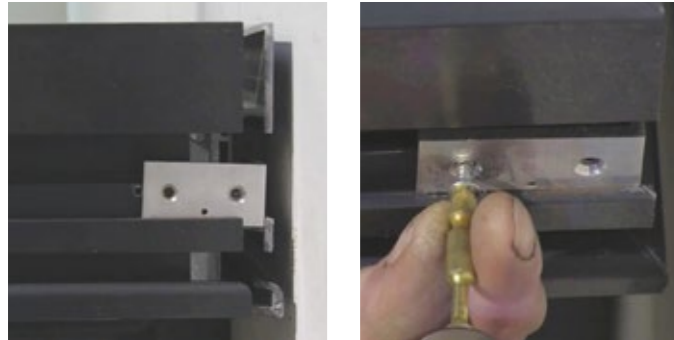

FIGURE 1

A-FRAME PREPARATION & ASSEMBLY



12 Slide the side gutters over the angle corner brackets fixed to the rear box gutter and fix with screws.



13 Fit the front gutter by hooking it onto the pre-fixed hanger plate.



1 Layout the routed ridge, central rafters and tie bars on the ground.



2 On a hidden tie bar, push the steel bracket into the routed side of the central rafters.

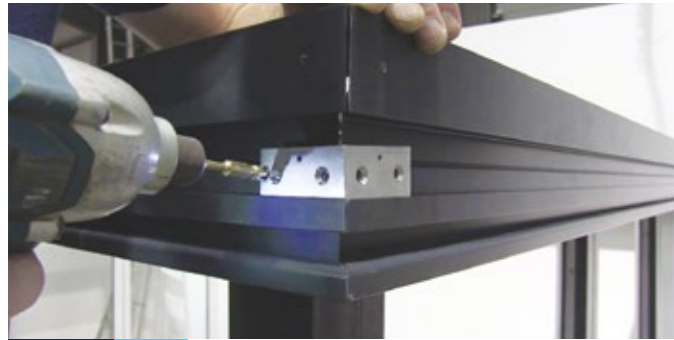

14 Tighten the joints by screwing an angled corner bracket into the adjoining aluminium gutters.



15 Screw the aluminium gutters and the ringbeams together at approx 400mm centres.



3 Engage the rafter bracket into the slot provided on the ridge.



4 Slide the rafter over the bracket, making sure it locates in the central bracket channel.



16 Cover the inside of the aluminium box gutters at the corners with sealant.

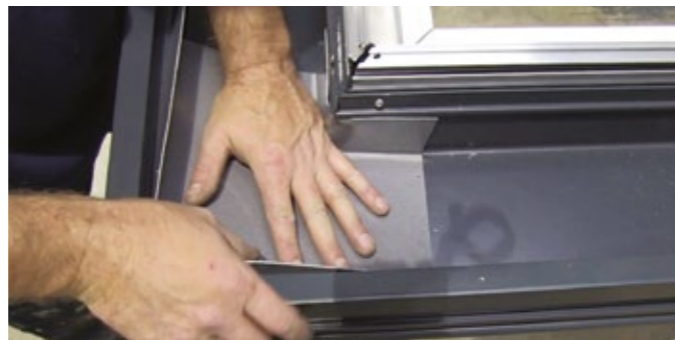

17 Push the plastic moulded corners inside the corners of the aluminium box gutters.



5 Screw into position by fixing the top screw.



6 Slide the adjacent rafter over the steel angled bracket.

RAFTER ASSEMBLY



7 Place the rafter into the slot on the ridge and slide the rafter up.



8 Screw into position by fixing the top screw.



1 Slide the ridge end rafter over the pre-fixed ridge bracket.



2 Tighten the pre-fixed screw to secure the ridge end rafter.



9 Fix remaining rafters on the main A-frame.



10 Lift the main A-frame into position.



3 Fix the opposite ridge end rafter.



4 Slide the hip rafter over the bracket and push it tight against the ridge.

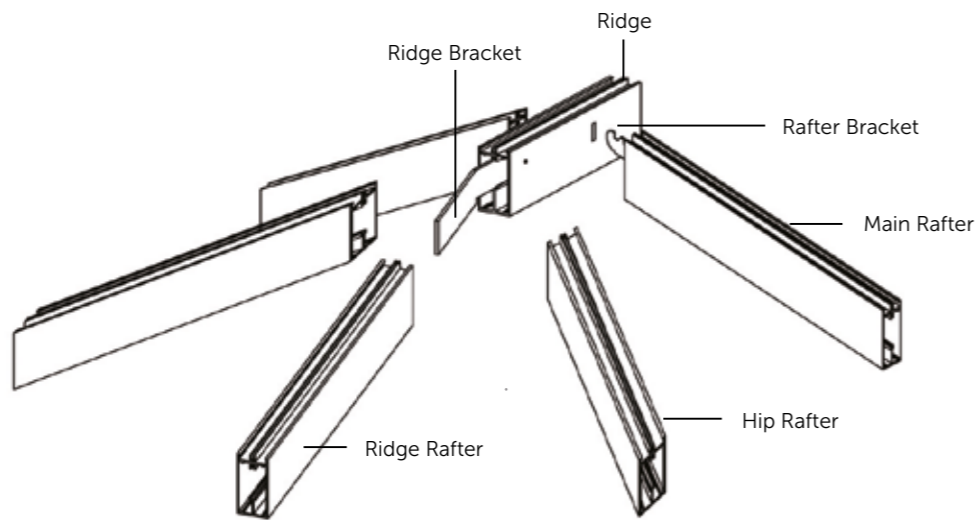

RIDGE ASSEMBLY

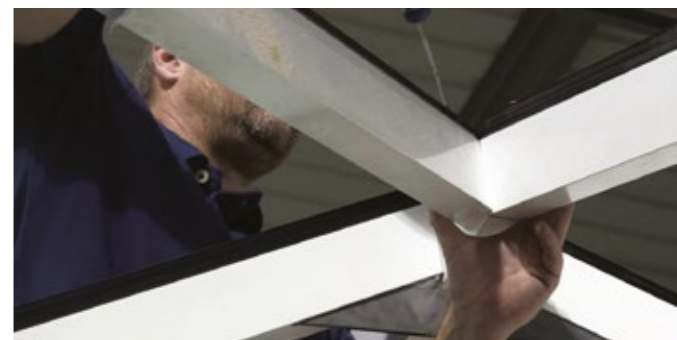

5 Secure the hip rafter by fixing the top screw.



6 Rotate the ringbeam flaps keeping them tight against the hip rafter cut before fixing.

GLAZING



7 Before fixing down the rafters, temporarily fit foam boards against flap to correctly space rafter positions.

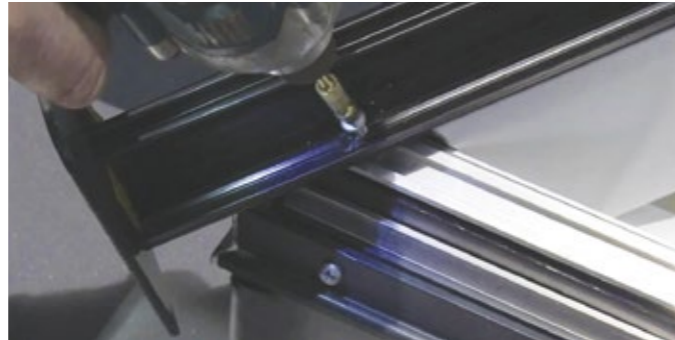

8 Fix each side of the hip glazing seat into the ringbeam flaps.



1 Once rafters are fixed, remove the foam boards and locate the glazing shelf.



2 Glue packers into place at bottom glass end closers.



9 Once the rafters are in position pull the ringbeam flap up tight to the rafter and fix centrally with a screw (see Figure 2).

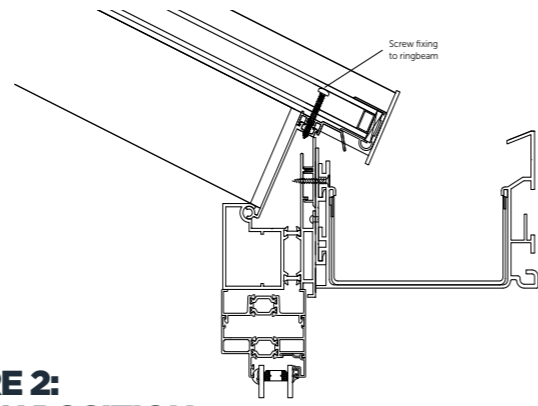
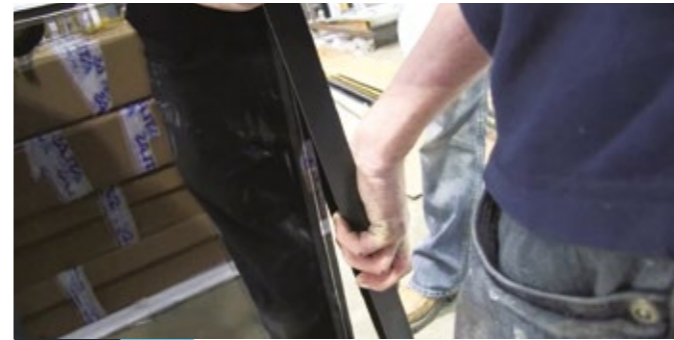

FIGURE 2: SCREW POSITION



3 Slide glazing end closer over the bottom of the glazing.



4 Lift glass into place behind the rafter end stops and press down glazing. Make sure the protective yellow tape is removed.



IMPORTANT NOTE:

It is vital when box gutters are required that adequate support is considered in the way of brick piers or gallow brackets. Always fix the gallow brackets and packer **before** the roof is glazed.



5 Fit all the rear units of glass keeping the glazing end closer between the rafters.



6 Position the plastic central pressure plate over rear rafters and fix with screws.

INTERNAL RINGBEAM

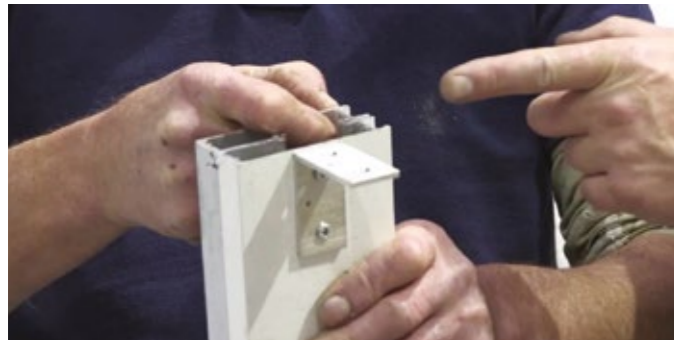

1 Fix angle cleat to the side of the upper ringbeam.



2 Slide the upper ringbeams into position between the rafters.



3 Screw through the angle brackets into the side of the rafters.

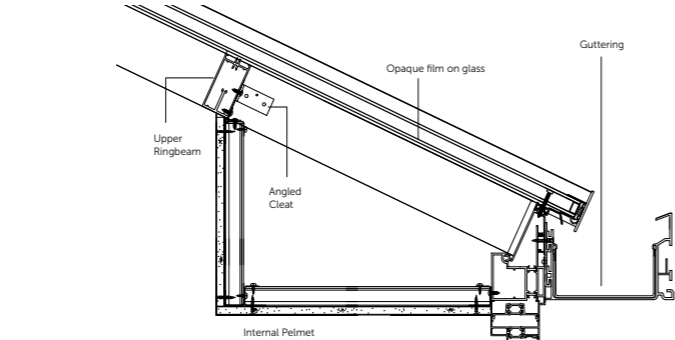

FIGURE 3: CLEAT POSITION



4 Screw fix the upper ringbeams through the pilot holes provided into the side of the hip rafter.



5 Fit the remainder of the upper ringbeams into position.

PRESSURE PLATE & COVER CAP



1 Glaze the remainder of the roof once all the upper ringbeams are fitted.



2 Fit remaining pressure plates into position.



3 Centralise the ridge pressure plate between the rafter pressure plates.



4 Fix the ridge pressure plate centrally to the main ridge body with screws.



5 Position the ridge cover cap over the ridge pressure plate and clip down securely. Clip on the external cover caps.

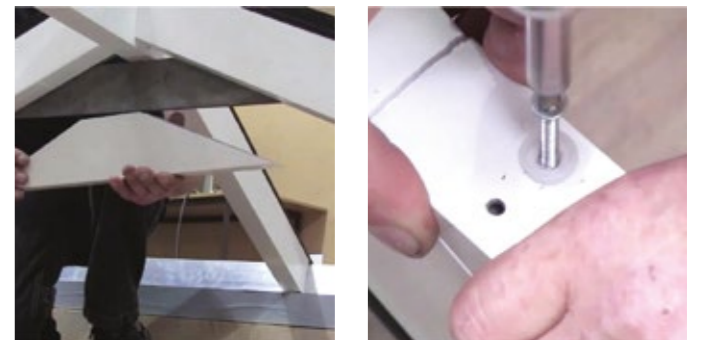

6 Fit the gusset cover over the hidden tie bar. Secure with screws.

CORNICE INSTALLATION



1 Lift the external cornice into position by positioning them at the bottom edge of the aluminium gutter and let them drop into place (see Figure 4).



2 Fit remainder of cornices.



7 Drill the top mushroom screw through the cornice into the bracket held at the back of the cornice.

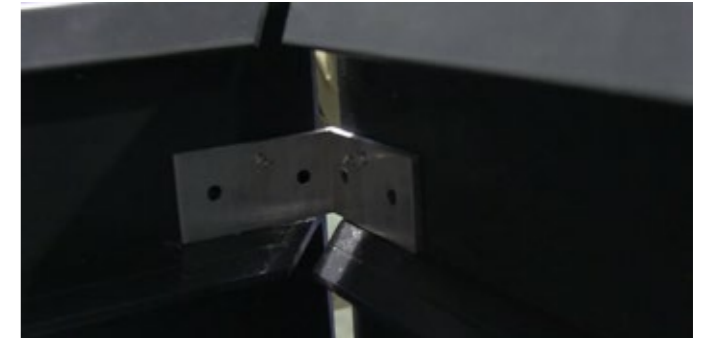

8 Mushroom screws are tightened to hold corner square. Stick on the arrow shaped flat trim to the underside of the gutter to conceal the joint.



3 Mark out the cornice 70mm and 210mm from the bottom.

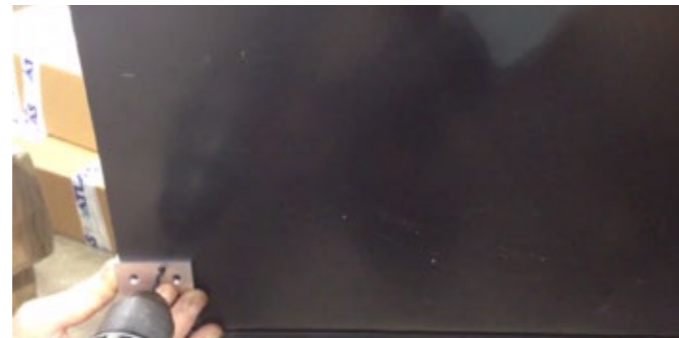

4 Firstly use the cornice bracket to mark the 70mm hole. Drill through the small pilot hole, but only mark the aluminium cornice.



9 Slide the finishing corner cornice angle over the mushroom screws by sliding them up from below.



10 Fix the aluminium cornice support straps with screws from the top of the aluminium rafter cover cap to the back of the external cornice at each rafter.



5 Use the cornice bracket again to drill the top 210mm hole right through the cornice.



6 Screw the bottom mushroom screw through the semi-drilled holes in the cornice. On the top hole line through the smaller hole on the bracket internally with the drill hole on the cornice.



11 Drill a circular hole in the aluminium gutter to create the downpipe outlet.



12 Screw the outlet connector provided into the hole and tighten.

INTERNAL PELMET



1 Centralise the vertical ladder frame onto the horizontal bottom frame and fix together with the screws provided.



2 Lift the longer ladder frame into position between the ringbeams.



3 Fix the hinge attached to the ladder frame onto the inside of the upper ringbeams. Make sure ladder frames are level before securing.



4 When frames are level fix the ladder frame to the back of the ringbeam (see Figure 5).



5 Fix the remainder of the ladder frame making sure the internal corners are securely fitted.



6 Screw plasterboard into the steel ladder grids.

FIGURE 4: CORNICE INSTALLATION

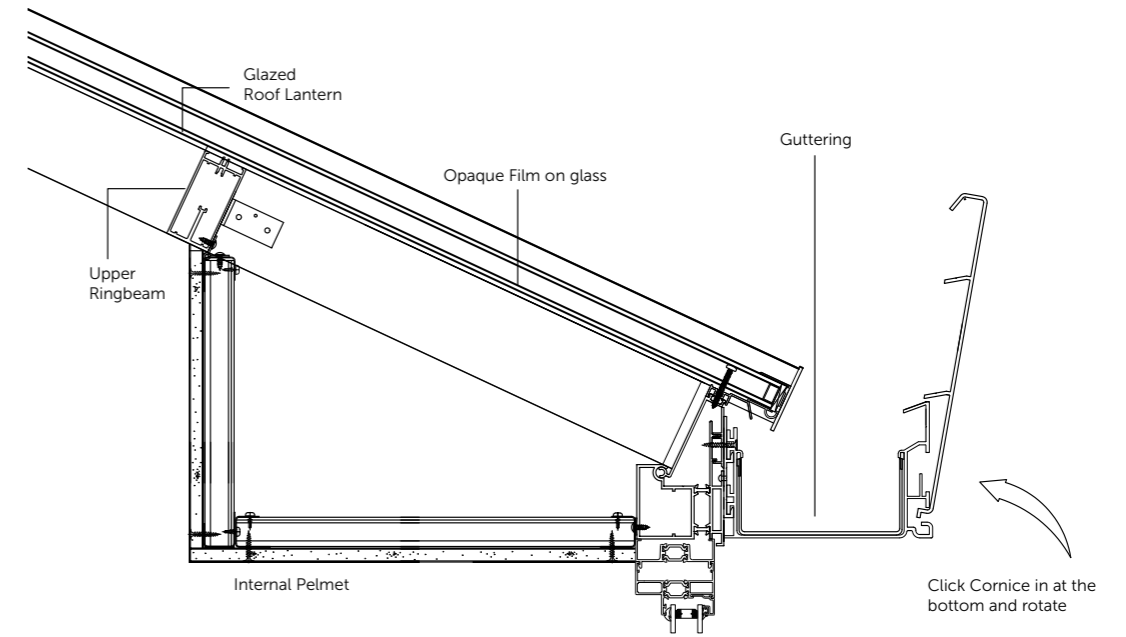
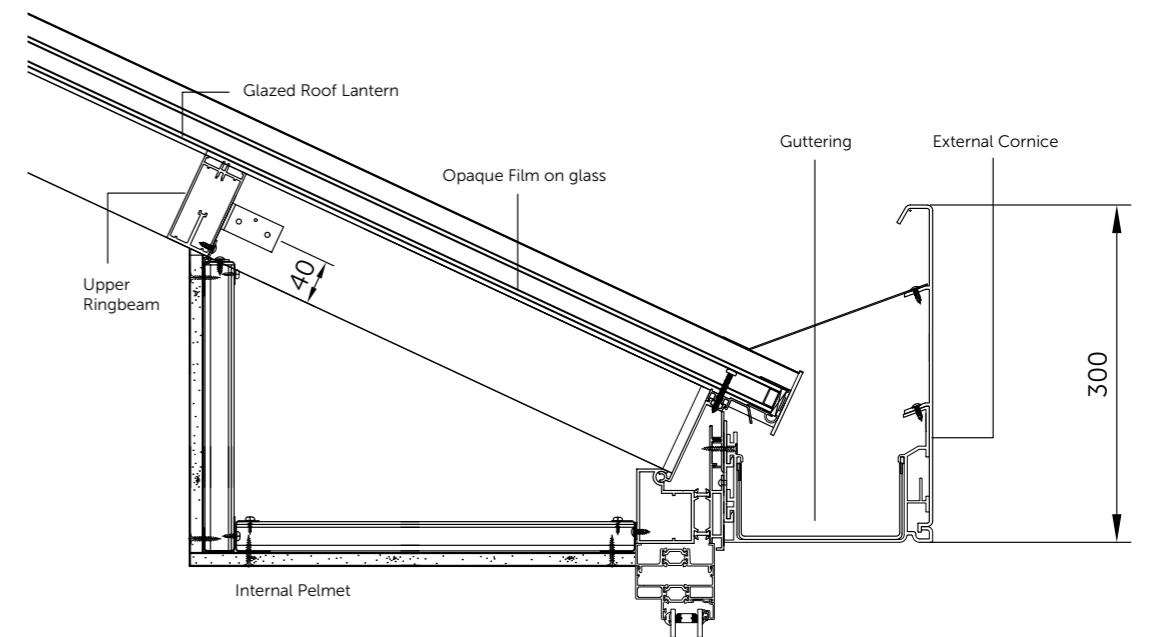
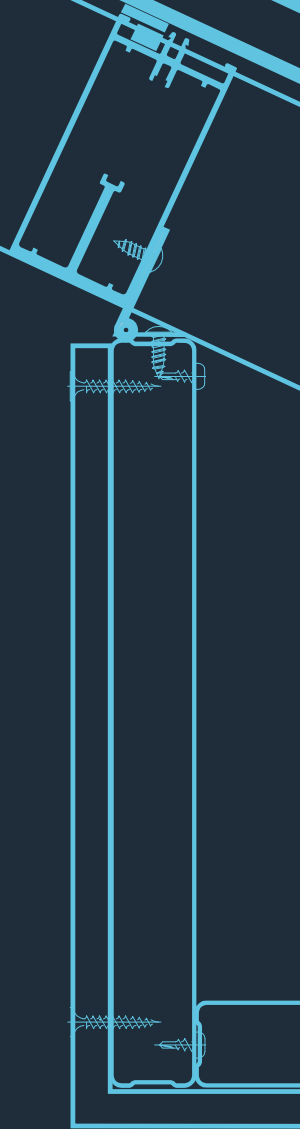

FIGURE 5: RINGBEAM SECTION



SKYROOM
INSTALLATION MANUAL



www.atlas-aluminium.co.uk
sales@atlas-aluminium.co.uk
01453 826884